

ITEM NO.	PART NUMBER	DESCRIPTION	QTY.
1	700064	WASHER #4 FLAT	2
2	A19304-2	SCR, PAN HD, #4-40 x 0.375", SST	2
3	A29675	SPECIAL SHOULDER SCREW	2
4	A30279	(Ri) RETAINER RING 5103-12	2
5	923067	SPACER (RCVR BLK - SHOULDER SCREW)	2
6	A31872	ALIGNMENT PIN RECEIVER BLOCK	2
7	A31879	ALIGNMENT PIN RETAINER	2
8	B31880	RECEIVER BLOCK	1

REV.	DESCRIPTION	DFT	DATE	ECR NO.
A	INITIAL RELEASE	YAN ZHANG	4/6/2015	NIL
BA	CHANGING SPACER PN	S. GARCIA	4/12/2017	
C	ADDED AN "F" TO PART NUMBER IN TITLE BLOCK	K.G.	1/22/2019	1076

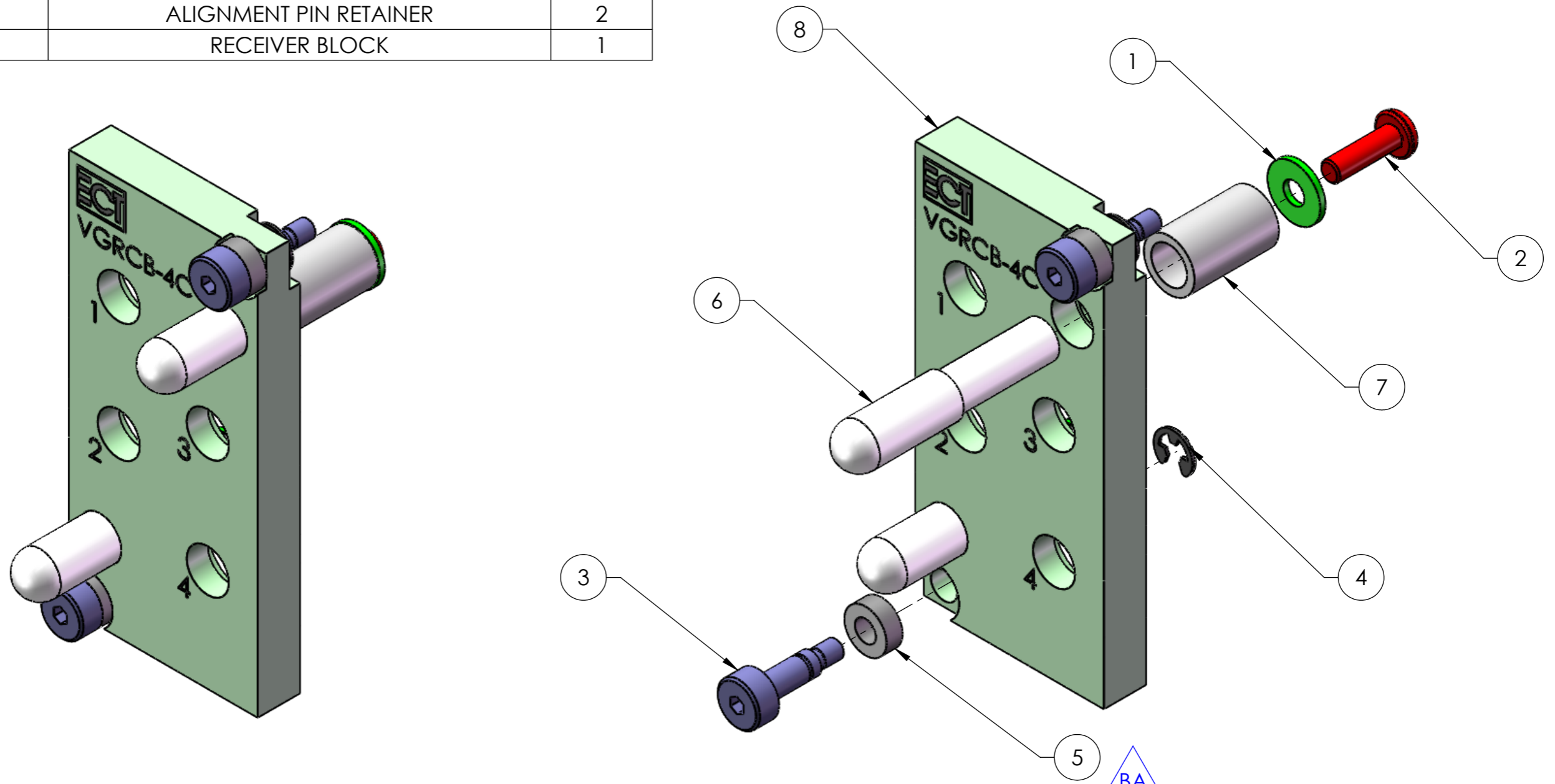

QTY: REFER TO BOM

- PLEASE NOTE:**
1. DIMENSIONAL LIMITS APPLY AFTER TREATMENT.
 2. REMOVE ALL SHARP EDGES.
 3. -

THIS DOCUMENT IS THE PROPERTY OF, AND CONTAINS INFORMATION PROPRIETARY TO **EVERETT CHARLES TECHNOLOGIES**. IT IS TO BE RETURNED UPON REQUEST. REPRODUCTION BY ANY MEANS, DISCLOSURE OR USE OF ITS CONTENTS FOR WHICH IT IS LOANED, WITHOUT WRITTEN CONSENT OF EVERETT CHARLES TECHNOLOGIES IS STRICTLY PROHIBITED.

UNLESS OTHERWISE SPECIFIED:
 1. DIMENSIONS ARE IN INCHES
 2. DEBURR ALL SHARP EDGES: .01 x 45°
 3. DO NOT SCALE DRAWING
 4. TOLERANCES: .ANGLES ± 0.5°
 .XX ± 0.02
 .XXX ± 0.005
 .XXXX ± 0.0005
 5. MACHINING REQUIRED:

PROJECTION:	
DRAWN BY:	YAN ZHANG
ENGR APVD	
MATERIAL	
TREATMENT	



TITLE					VGRCB-4CF				
SIZE	SCALE	DOCUMENT NUMBER	SHEET	REV					
A4	2:1	611	1 OF 1	C					