

ITEM NO.	PART NUMBER	DESCRIPTION	QTY.
1	A19304-1	SCR, PAN HD, #4-40 x 0.250", SST	2
2	A19304-2	SCR, PAN HD, #4-40 x 0.375", SST	2
3	A19304-4	SCR, PAN HD, #4-40 x 0.5", SST	2
4	A31053	ALIGNMENT BUSHING(FIXTURE BLOCK)	2
5	B31059	ALIGNMENT PLATE (30 POSITION)	1
6	B31063	FIXTURE BLOCK (30 POSITION)	1

REV.	DESCRIPTION	DFT	DATE	ECR NO.
A	INITIAL RELEASE	YAN ZHANG	2/27/15	NIL
BA	CHANGING ALIGNMENT PLATE THICKNESS TO 3MM	S. GARCIA	6/30/2017	
C	ADDED AN "F" TO PART NUMBER IN TITLE BLOCK.	K.G.	1/22/2019	1075

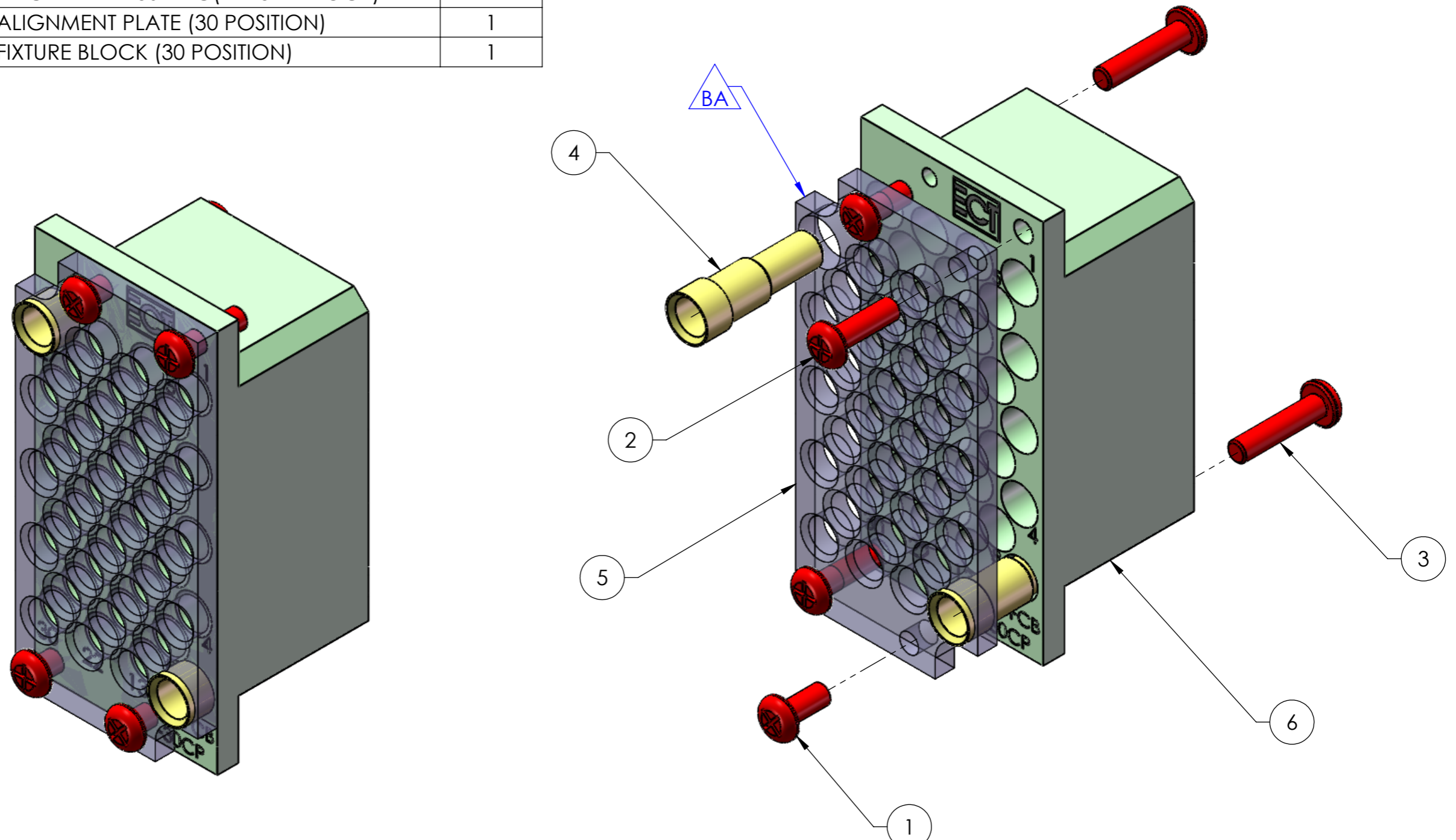

QTY: REFER TO BOM

PLEASE NOTE:
1. DIMENSIONAL LIMITS APPLY AFTER TREATMENT.
2. REMOVE ALL SHARP EDGES.
3. -

THIS DOCUMENT IS THE PROPERTY OF, AND CONTAINS INFORMATION PROPRIETARY TO **EVERETT CHARLES TECHNOLOGIES**. IT IS TO BE RETURNED UPON REQUEST. REPRODUCTION BY ANY MEANS, DISCLOSURE OR USE OF ITS CONTENTS FOR WHICH IT IS LOANED, WITHOUT WRITTEN CONSENT OF EVERETT CHARLES TECHNOLOGIES IS STRICTLY PROHIBITED.

UNLESS OTHERWISE SPECIFIED:
1. DIMENSIONS ARE IN INCHES
2. DEBURR ALL SHARP EDGES: .01 x 45°
3. DO NOT SCALE DRAWING
4. TOLERANCES: .ANGLES ± 0.5°
 .XX ± 0.02
 .XXX ± 0.005
 .XXXX ± 0.0005
5. MACHINING REQUIRED:

PROJECTION:	
DRAWN BY:	YAN ZHANG
ENGR APVD	
MATERIAL	
TREATMENT	



TITLE		VGFCB-30CPF		
SIZE	SCALE	DOCUMENT NUMBER	SHEET	REV
A4	2:1	526	1 OF 1	C