

ITEM NO.	PART NUMBER	DESCRIPTION	QTY.
1	A19304-2	SCR, PAN HD, #4-40 x 0.375", SST	2
2	B10783-1	CONTACT BLOCK (170 PTS)	1
3	EPA-2B40	(Ri) PROBE	85
4	SPR-2W-2	A RECEPT SPR-2W-2	85

REV.	DESCRIPTION	DFT	DATE	ECR NO.
A	INITIAL RELEASE	YAN ZHANG	3/17/15	NIL
AB	ADDED SOCKET HEIGHT INSTRUCTION	D.HERNANDEZ	8/22/2016	NIL
B	ADDED ALIGNMENT CALL OUT FOR RECEPTACLES	K.G.	9/5/2018	1050

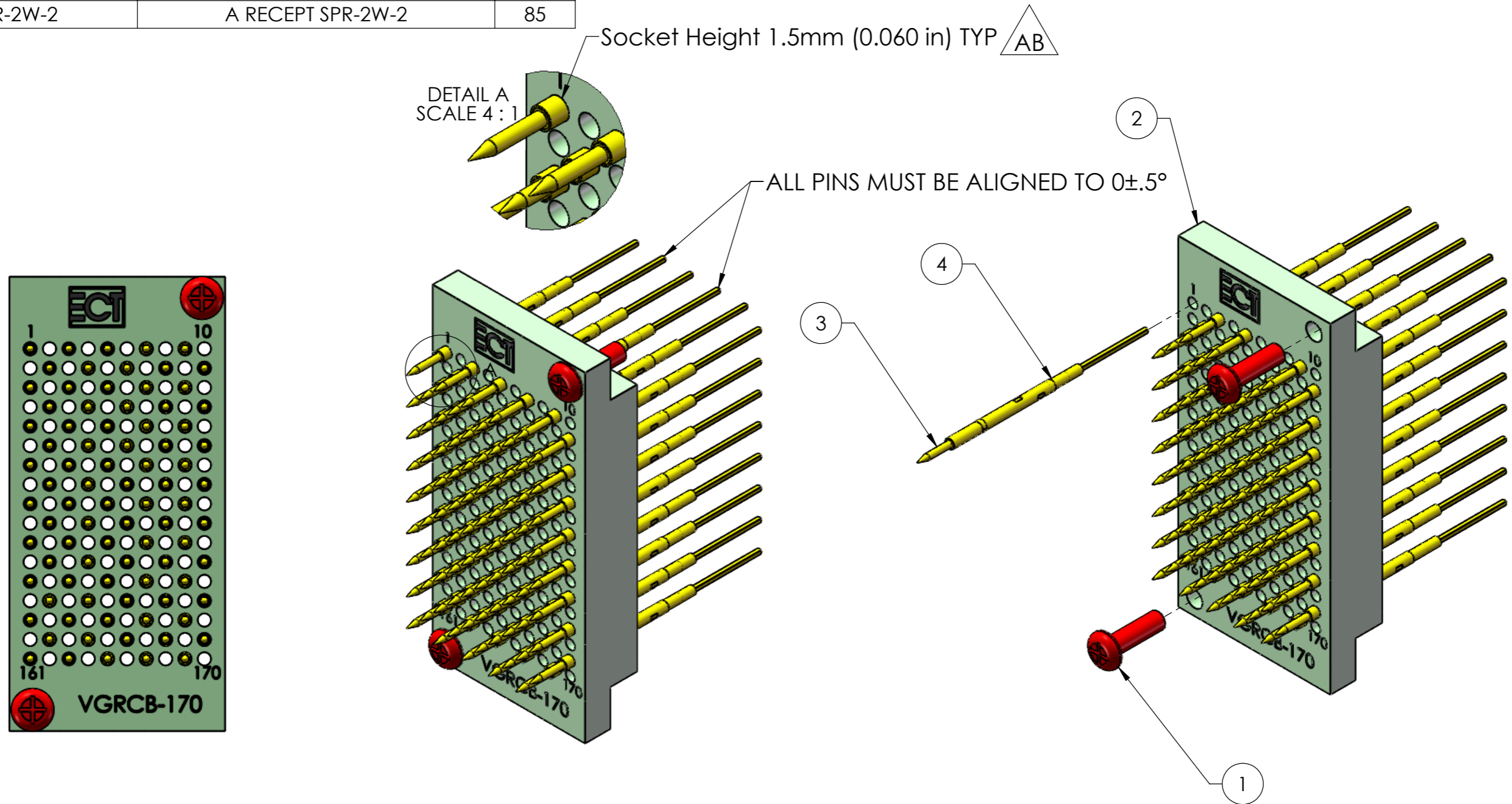

QTY: REFER TO BOM

PLEASE NOTE:
 1. DIMENSIONAL LIMITS APPLY AFTER TREATMENT.
 2. REMOVE ALL SHARP EDGES.
 3. -

THIS DOCUMENT IS THE PROPERTY OF, AND CONTAINS INFORMATION PROPRIETARY TO **EVERETT CHARLES TECHNOLOGIES**. IT IS TO BE RETURNED UPON REQUEST. REPRODUCTION BY ANY MEANS, DISCLOSURE OR USE OF ITS CONTENTS FOR WHICH IT IS LOANED, WITHOUT WRITTEN CONSENT OF EVERETT CHARLES TECHNOLOGIES IS STRICTLY PROHIBITED.

UNLESS OTHERWISE SPECIFIED:
 1. DIMENSIONS ARE IN INCHES
 2. DEBURR ALL SHARP EDGES: .01 x 45°
 3. DO NOT SCALE DRAWING
 4. TOLERANCES: .ANGLES ± 0.5°
 .XX ± 0.02
 .XXX ± 0.005
 .XXXX ± 0.0005
 5. MACHINING REQUIRED:

PROJECTION:	
DRAWN BY:	YAN ZHANG
ENGR APVD	
MATERIAL	
TREATMENT	



TITLE					A VGRCB-85H				
SIZE	SCALE	DOCUMENT NUMBER	SHEET	REV					
A4	1.8:1	820491	1 OF 1	B					