

ITEM NO.	PART NUMBER	DESCRIPTION	QTY.
1	A12476	PIN, SOLID DUMMY (.030 LG, HEAD)	85
2	A19304-2	SCR, PAN HD, #4-40 x 0.375", SST	2
3	B10031-S	INTERFACE BLOCK 170 PTS (FOR SQUARE TAILS)	1

REV.	DESCRIPTION	DFT	DATE	ECR NO.
A	INITIAL RELEASE	YAN ZHANG	3/23/2015	NIL
AB	ADDED INSTRUCTION PIN ORIENTATION	D.HERNANDEZ	8/16/2016	NIL
BA	UPDATED THE PIN DIAMETER INTERFACE BLOCK TO 1.55mm	D.HERNANDEZ	10/17/2016	NIL
CA	UPDATE ITEM No. 3	RAFAEL D.	12/19/2016	NIL

ALL PINS MUST BE ALIGNED TO 0 +/-0.5 DEGREES

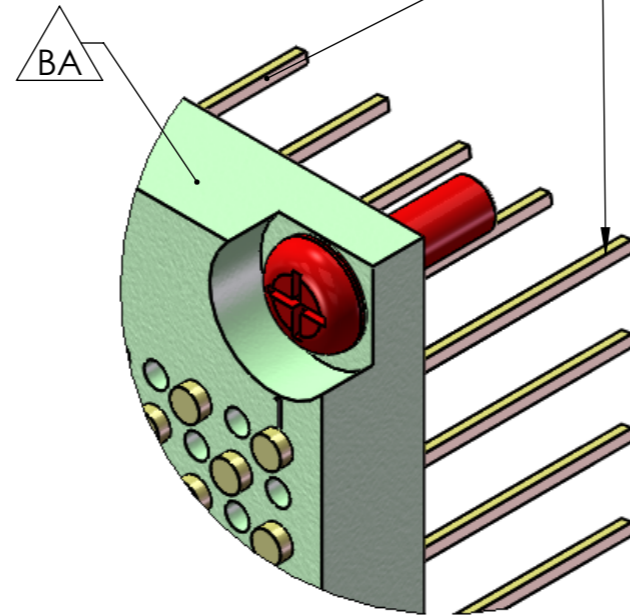
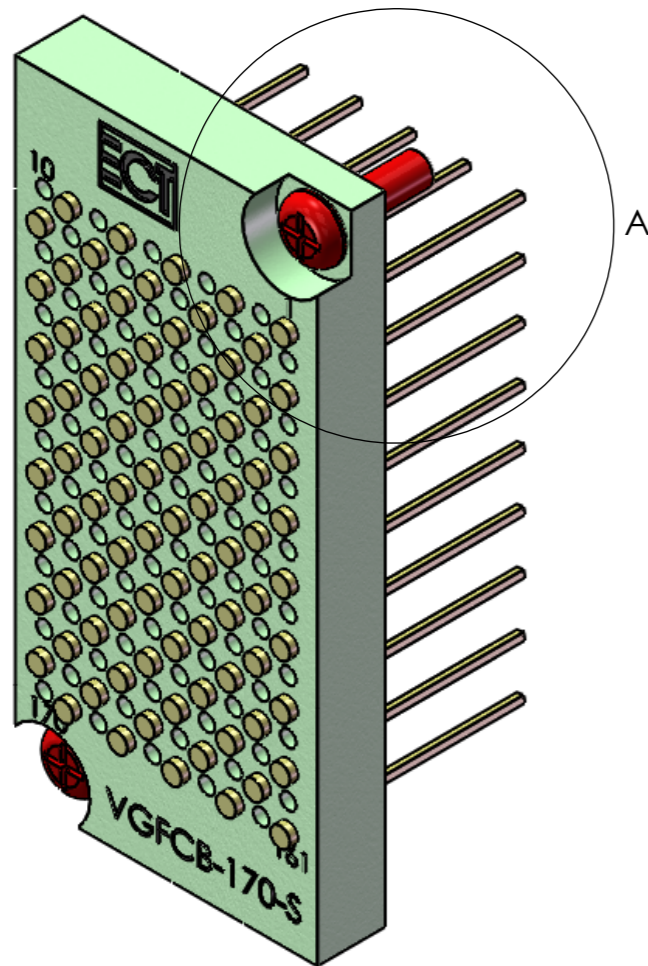

DETAIL A
SCALE 3:1

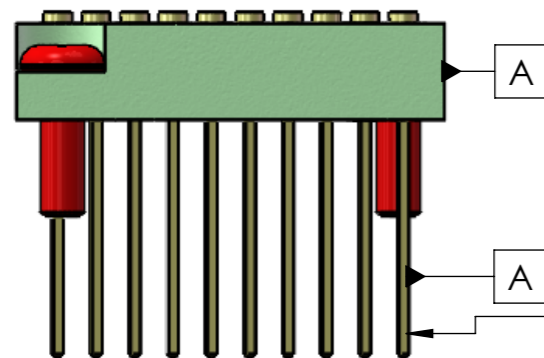
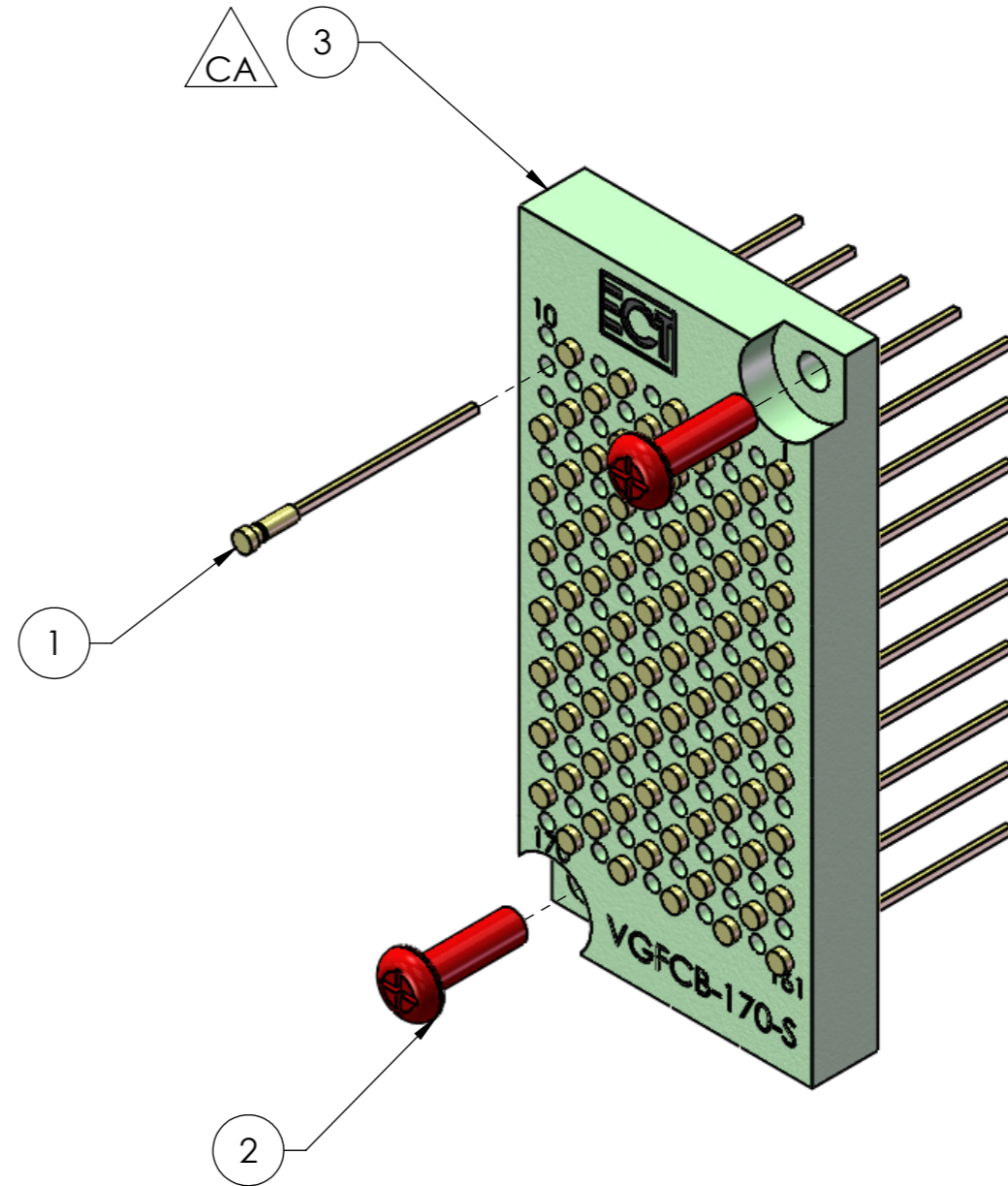

0° +/-0.5°

QTY: REFER TO BOM

- PLEASE NOTE:**
1. DIMENSIONAL LIMITS APPLY AFTER TREATMENT.
 2. REMOVE ALL SHARP EDGES.
 3. -

THIS DOCUMENT IS THE PROPERTY OF, AND CONTAINS INFORMATION PROPRIETARY TO **EVERETT CHARLES TECHNOLOGIES**. IT IS TO BE RETURNED UPON REQUEST. REPRODUCTION BY ANY MEANS, DISCLOSURE OR USE OF ITS CONTENTS FOR WHICH IT IS LOANED, WITHOUT WRITTEN CONSENT OF EVERETT CHARLES TECHNOLOGIES IS STRICTLY PROHIBITED.

- UNLESS OTHERWISE SPECIFIED:
1. DIMENSIONS ARE IN INCHES
 2. DEBURR ALL SHARP EDGES: .01 x 45°
 3. DO NOT SCALE DRAWING
 4. TOLERANCES: .ANGLES ± 0.5°
.XX ± 0.02
.XXX ± 0.005
.XXXX ± 0.0005
 5. MACHINING REQUIRED:

PROJECTION:	
DRAWN BY:	YAN ZHANG
ENGR APVD	
MATERIAL	
TREATMENT	



BLK161 KALLANG WAY #06-18/26
SINGAPORE 349247
TEL: (65) 62938966 FAX: (65) 62939866

TITLE		A VGFCB-85		
SIZE	SCALE	DOCUMENT NUMBER	SHEET	REV
A4	2:1	820492	1 OF 1	CA