

ITEM NO.	PART NUMBER	DESCRIPTION	QTY.
1	A19304-1	SCR, PAN HD, #4-40 x 0.250", SST	2
2	A19304-4	SCR, PAN HD, #4-40 x 0.5", SST	2
3	A31053	ALIGNMENT BUSHING(FIXTURE BLOCK)	2
4	B35465	BLOCK, FIXTURE 26 GHZ	1
5	B35466	PLATE, ALIGNMENT 26 GHZ	1

REV.	DESCRIPTION	DFT	DATE	ECR NO.
A	INITIAL RELEASE	YAN ZHANG	4/6/2015	NIL

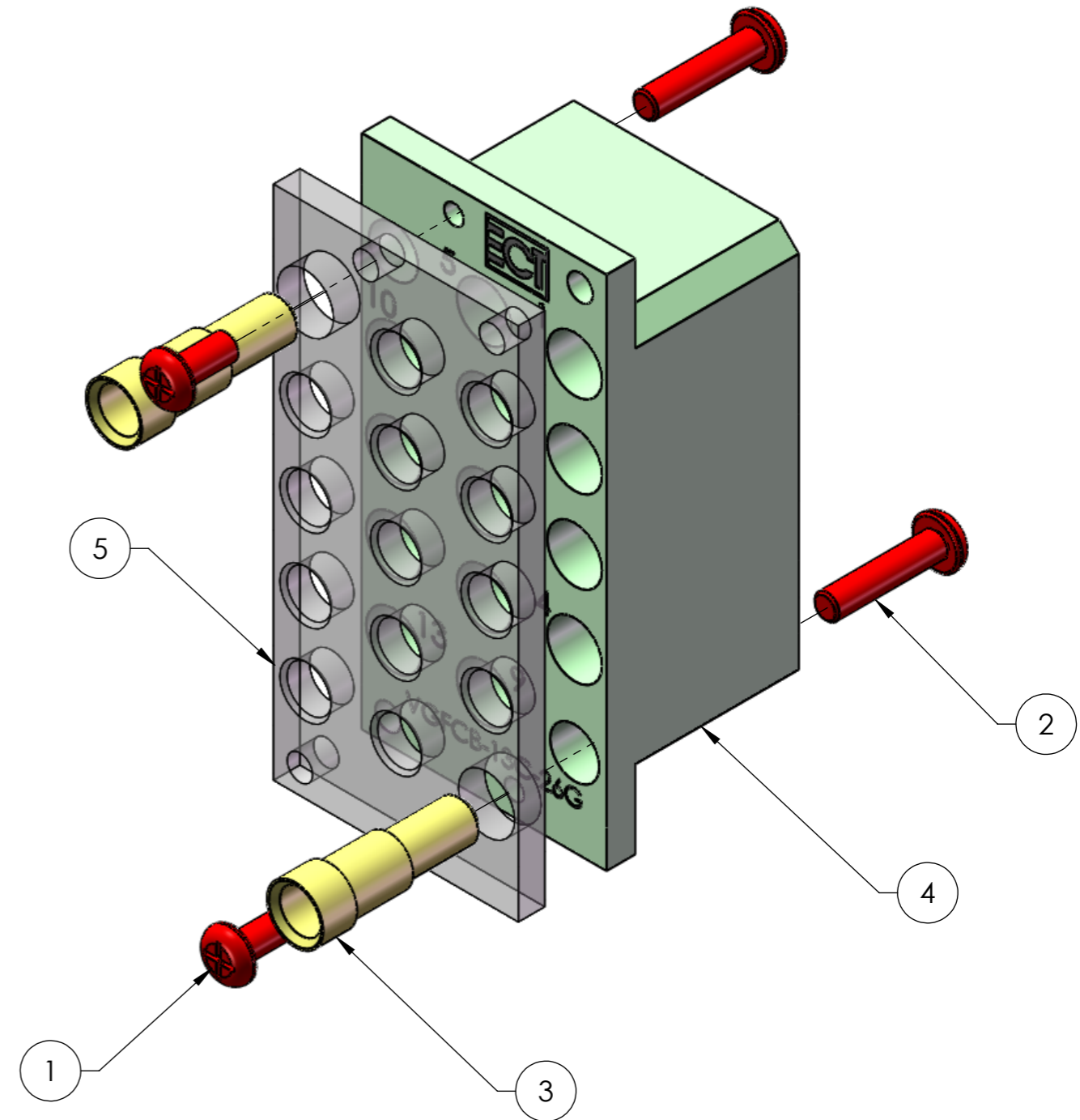
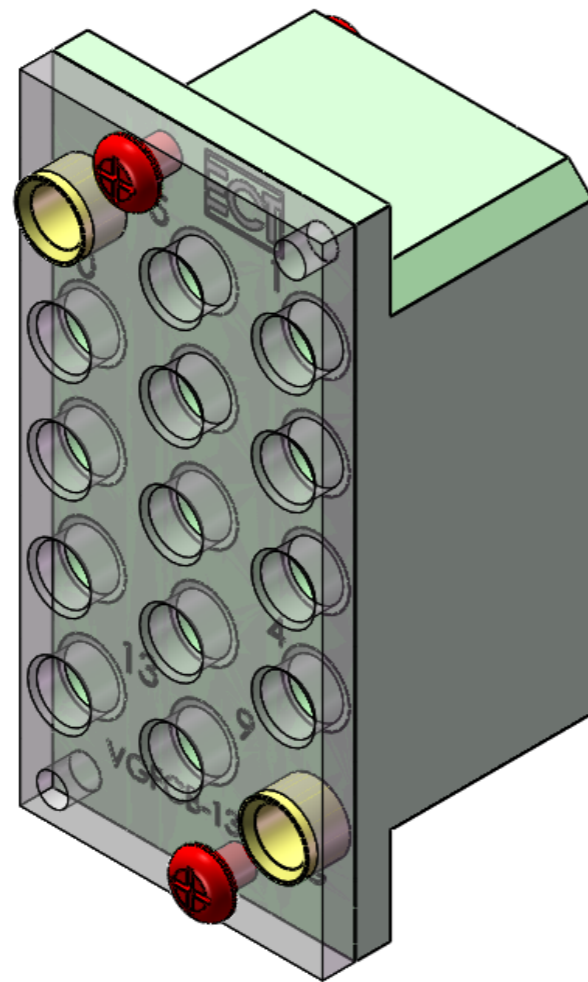

QTY: REFER TO BOM

PLEASE NOTE:
 1. DIMENSIONAL LIMITS APPLY AFTER TREATMENT.
 2. REMOVE ALL SHARP EDGES.
 3. -

THIS DOCUMENT IS THE PROPERTY OF, AND CONTAINS INFORMATION PROPRIETARY TO **EVERETT CHARLES TECHNOLOGIES**. IT IS TO BE RETURNED UPON REQUEST. REPRODUCTION BY ANY MEANS, DISCLOSURE OR USE OF ITS CONTENTS FOR WHICH IT IS LOANED, WITHOUT WRITTEN CONSENT OF EVERETT CHARLES TECHNOLOGIES IS STRICTLY PROHIBITED.

UNLESS OTHERWISE SPECIFIED:
 1. DIMENSIONS ARE IN INCHES
 2. DEBURR ALL SHARP EDGES: .01 x 45°
 3. DO NOT SCALE DRAWING
 4. TOLERANCES: .ANGLES ± 0.5°
 .XX ± 0.02
 .XXX ± 0.005
 .XXXX ± 0.0005
 5. MACHINING REQUIRED:

PROJECTION:	
DRAWN BY:	YAN ZHANG
ENGR APVD	
MATERIAL	
TREATMENT	



BLK161 KALLANG WAY #06-18/26
 SINGAPORE 349247
 TEL: (65) 62938966 FAX: (65) 62939866

TITLE		C VGFCB-13C-26		
SIZE	SCALE	DOCUMENT NUMBER	SHEET	REV
A4	2:1	916	1 OF 1	A